

HERMITAGE | HEC005 + HEV002

Vaso S + cassetta zaino 53*36*38.5 + 40*21*42

Wc with floor drain + low level ceramic cistern 53*36*38.5
+ 40*21*42

PESO/WEIGHT: KG 14+ 19

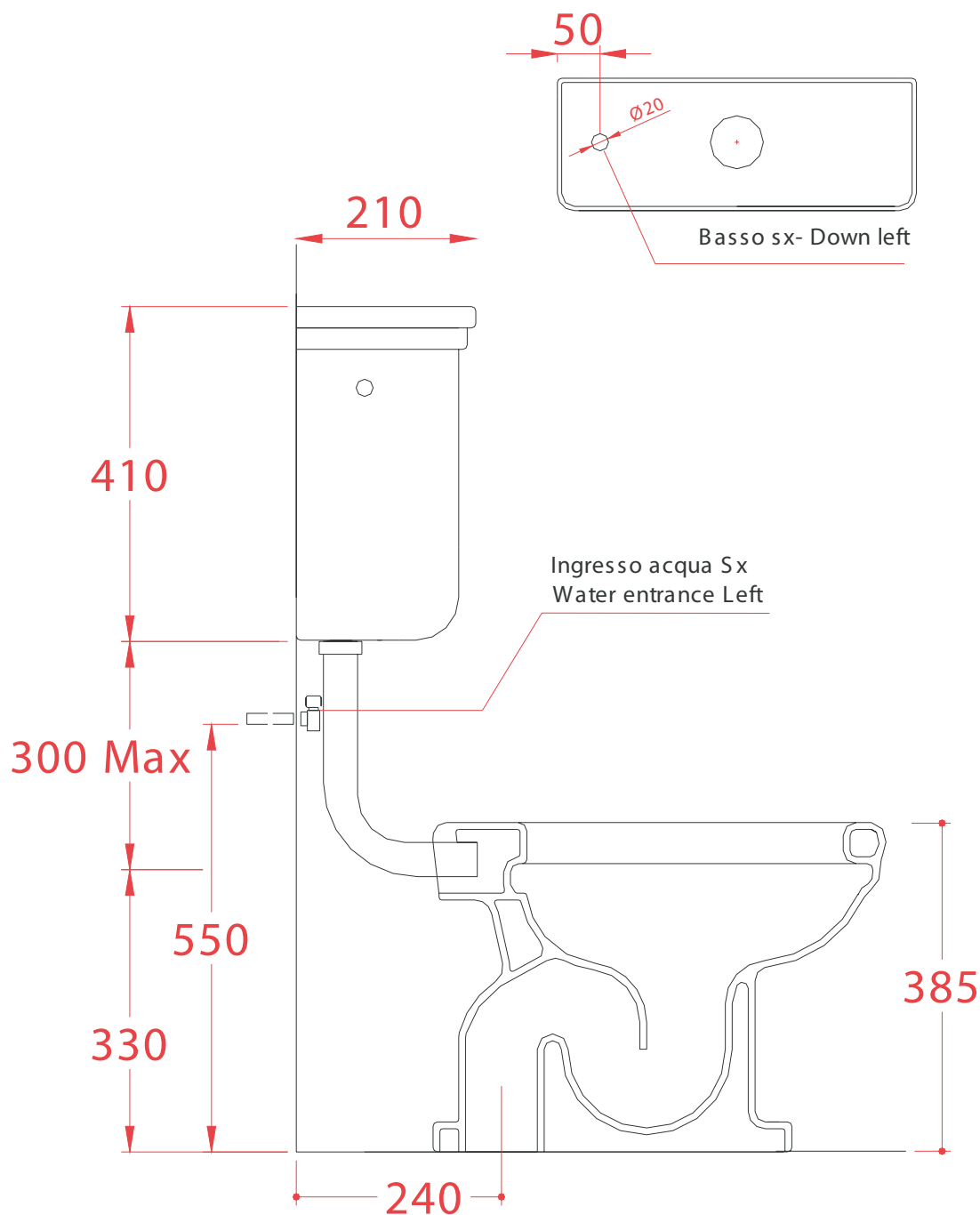

N.B. Le misure indicate possono subire una variazione dell'0,6% circa, dovuta ad usura stampi e a variazioni delle caratteristiche tecniche relative alle materie prime che compongono l'impasto.

N.B. Indicated size could have a variation of about 0,6% due to usure of the moulds or the variations of the materials' technical characteristics used in the mixture.